

सोने

की

चिड़ीया

*(golden bird)*

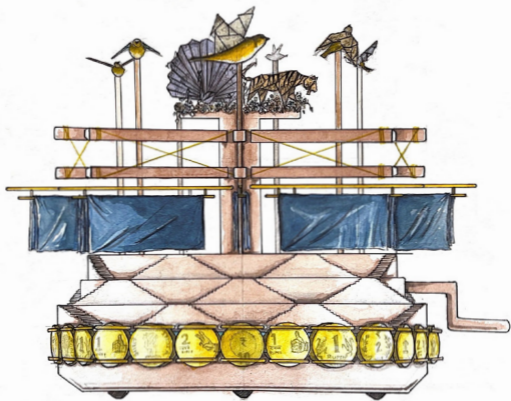

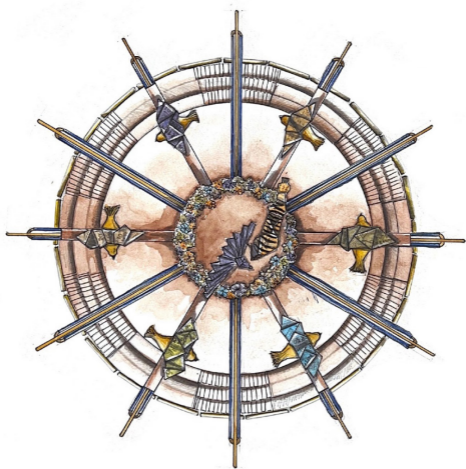

## **'Sone ki Chidiya' Carousel**

Our carousels are a succinct representation of the notion of human-powered mechanics which in turn guide and determine intangible aspects such as growth and movement. The intentional avoidance of electric powered mechanisms invoke a continuous relevance of the piece now and much later, longevity and durability.

The piece represents a burgeoning energy waiting to be harnessed in the country to take it to new heights in the world.

We envision this piece as a vehicle to carry us as a collective whole (whole greater than sum of all parts, but each part being a whole in itself too!) projecting in the future. The time is right now - our country has a shining present and an even more promising future. The onus is on each one of us to harness this energy and use it responsibly to create beauty and meaning that outlasts us as individual beings. Whatever we do right now would be an invaluable part of the rich legacy that our country is sure to create from everything that is sprouting up in these fertile times!

## Step-wells

The step-well is an ingenious piece of architecture originating in the subcontinent as a means of storing an ever-scant resource, water and making it available: a watering hole carved into the ground and then bound and retained by stone steps.

One goes down into the step-well till the level of the water: the step-well imbibes memories of the different levels of water it holds over time. Each step is derived from human proportions, making it accessible for one to walk to precisely that point and fetch.

The geometries of this large architectural 'container' are awe-inspiring. The word 'vessel' means two things: container and boat, one envelops you and the other transports you. Both words are perhaps contrary in literal meaning but they drive a poignant point – step-wells are sublime places, ones that provide gorgeous backgrounds to celebrate otherwise mundane life activities like washing clothes, bathing and so on. The steps in a step-well are all the same, equalizing everybody into a larger glorious fabric, perhaps driving a sense of community and belonging through everybody who is there, presenting each performance through its subtle varieties but ultimate likeness.



"A well that stares at the sky is like an unblinking eye. A sliver of sky that bathes in its own reflection."

Raqs Media Collective (Khoj Studios)

Step-wells are a standing testament to the times that were, of ingenuity, of manifesting profound ambitions of our material culture and capturing lessons of the everyday in the very many practices that unfolded here since time immemorial. The step-wells are a quiet wonder, still and yet dynamic.

## Charkha

One intrinsic practice to our land is the spinning wheel and by extension, the looms to weave resplendent fabrics. This is less a craft and more a livelihood, perhaps a way of life itself, a spiritual practice of creation and worship. Cloth was attributed sacredness, so much so that it was considered sin to cut handwoven cloth.

The perpetuity of such a practice was ensured for eras for it provided one of the basic needs of civilization itself - cloth. Today, the handlooms face massive decline - the practice is gatekept in minuscule contained pockets only, leading to a mass-erosion of the prolific lived knowledge pervading much larger communities then. These practices were evolving everyday and the trials and errors that each cluster iterated led to an elevation of the actual material and how.







## Hand-powered practices

These practices are encapsulated in the simple spinning of the charkha, signifying human effort, consistency, repetition, discipline in an almost meditative manner – our fabrics (and other such material) are not just what meets the eye but actually reveal these richly led lives where each experience in itself is enough to merge one with the higher power.

The wheel of growth and progress, spins cohesively and rhythmically, singing together in unison. Golden threads spun with the charkha allude to the bygone years of our fabulous hand-woven fabrics thriving the international clothing markets, and our people asking for nothing but gold in return. This is how India came to be known as the land of the 'Golden Sparrow'.

Our hand-powered carousel or 'ghum-chakri' is an ode to the Sone ki Chidiya. The carousel is imagined as a vehicle to carry us into the future: while carrying the legacy of our past, participating in the rich dialogues which brought us here to this point today and relaying them ahead. The organic indigo dyed khadi 'sails' are catching the winds of change and guiding direction for us to stay continuously relevant in our endeavours.

## Sacred Botanicals of India

This carousel accumulates diversity in a few ways. The sail clothes in indigo are hand-embroidered with sacred plants indigenous to the subcontinent. These have medicinal value and lend myriads of miraculous experiences to the atmosphere if one stops and looks. These are a reminder for us not to neglect nature even if just for the sake of beauty.

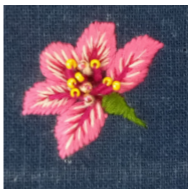

## Diamond Polishing in Surat

SHED has a shared history with the Dholakia family as we are based out of Surat and come from the diamond manufacturing lineage. We brought in a few 'cots' from the family factory and mounted stones, marbles, woods, metals and glass into them and then faceted them just like one would a diamond. A cot is a mechanical arm or clamp to hold the piece above a rotating polishing wheel which facets or smoothens the material as it is pressed against the wheel; there are ways to turn the job equidistant so one achieves precise facets. This unique collaboration helped us know more intimately the practice of diamond polishing, one of the most prevalent industries here in Surat and arguably our backbone! This is one where cutting-edge technology has evolved over the years and some of the finest workmanship is found in the bylanes of Varachha: a thriving and successful industry which has served many generations.

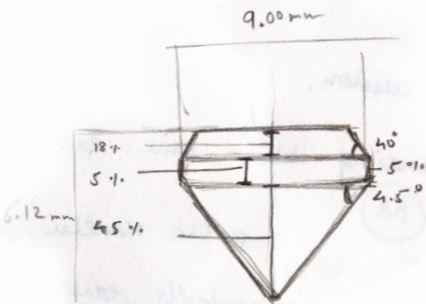







## Birds

Mechanically animated flying birds plated in 22 carat gold hover over the carousel, circling the *chabutra* (bird-house): as one cranks the handle, the disc at the base of the carousel where the coins are studded rotates along with the birds going in the opposite direction.

The golden sparrow invokes a free and fluttering India yet again, one that is soaring into the future, like it was once historically known to be one of the most prosperous civilisations in the history of mankind.







## Coins

At the base of the step-wells, one finds 'coins' on this carousel. Our own practice at the SHED has been to deeply delve into material stories and fetch meaning from them. We were interested in breaking open the dialogue and invite our fraternity of makers to add yet one more layer of diversity and collectivism.

The coins studded at the bottom of the carousel are all individual bits of materiality and techniques that speak of design and making practices in different parts of the country. We want to represent these 30 odd slots as (one of the many) currencies for growth in the country: innovation, storytelling, material knowledge, design, art, craft, tradition all co-exist here to create a progressive living culture.









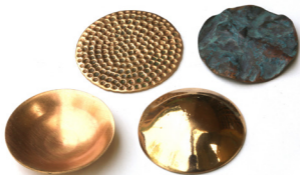

*Development has a direct link to the built environment – it may enable societal progress, is a precondition for our modern society's productivity and plays a major role in shaping people's way of life and wellbeing. On the other hand, the built environment is also a material, spatial and cultural product of human labor and imagination. Its structure, form, function and the quality of its natural environment determine its suitability for human habitation.*

*In an age of globalization, constant development and power struggles, the notion of progress often tends to indulge in stereotypes within the built environment. With a focus on remaining in the Westphalian mode, the perception of development sometimes is reduced to a mere visual. Considering the rapid urbanization shift facing Indian cities today, will this unipolar approach render the institutional mechanism of these cities, irrelevant in the future?*

*The installation is an attempt to answer this question. It brings a multi-layered approach, a nuanced perspective to the forefront. This set of copper discs display a sensitive approach to the environment, with an innate ability to accommodate, adapt and evolve. The thin sheets of copper boldly embrace the surroundings – nuanced to change in physical position, light, temperature, salinity and touch. Subtle treatments of bending, polishing and hammering elevate these engagements.*



*The polished, concave discs converge and diverge light respectively – representing introspection and identifying ones self, while being receptive to learning and opportunity. The hammered and crumpled sheets are treated with acetic acid, salt and vinegar. Folded crevices deposit these layers, catalyzing the oxidization process – displaying a sensitive vulnerability and endurance of time.*

*These discs remain quiet, seamlessly conforming and elevating the experience of the carousel. Discreetly positioning themselves at the base; amidst other stories, these discs aim to illuminate the benefits of an inclusive and considered approach to policy-making, design and innovation and the profound impact it can have on our shared environment and society.*

*Krish Shah  
Principal architect, Otlá*

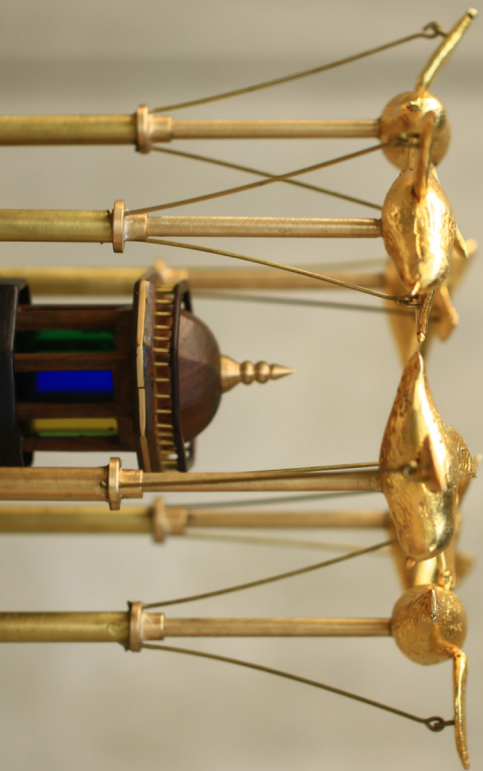









December, 2024

This carousel was  
commissioned  
by the kind patronage of  
Dhruval Dholakia and  
Govindbhai Dholakia  
of the  
**SRK family**  
with the intention of  
gifting it to the PMO.

*The views, ideas, and opinions expressed  
here are those of the artists and  
creators, and are not intended to reflect  
or represent any official position or  
policies of the Government of India or the  
Prime Minister's Office.*

# SHED

## *Credits*

### SHED team:

Priyanka Shah (Principal Designer)  
Swapnil Gange (Head Art Direction)  
Nika Shah (Textile and Fabric Direction)  
Keshvi Kharwar (Textile Designer)  
Dipak Desale (Mechanism Design and Lathe Turning)  
Rajendra Gohil (Lathe Turning)  
Anil Sharma (Carpenter)  
Uday Sharma (Carpenter)  
Naveen (Carpenter)  
Pawan Sharma (Carpenter)  
Vidhyasagar Nishad (Glass team)  
Amitesh Nishad (Glass team)  
Anil Nishad (Finishing team)  
Shravan Nishad (Finishing team)  
Harishankar Nishad (Finishing team)  
Ishwar Nishad (Indigo Dyeing)  
Aslam Ansari (Stitching)  
Ayub Ansari (Stitching)  
Mehmood Alam (Stitching)  
Dilshaadbhai (Hand Embroidery)  
Sohilbhai (Hand Embroidery)  
Nilesh Mankar (Production Coordinator)  
Ranchhod Patel (Production Coordinator)

### KG team:

Dipak Makvana (Diamond Fancy Shapes Specialist)  
Umesh Baldaniya (Diamond Polishing)  
Pritesh Shah (Production Head)

# SHED

*Credits*

## Coin Contributors:

Nitin Jain

Material Immaterial

Ritu and Surya Singh

Wolf Jaipur

Nika Shah

Lineage

Krish Shah

Studio Ota

Priyanka Shah

SHED

Muskan Jain

@muscellaneous\_

Swapnil Gange

SHED

Ankit Patel

Foolstop Design

Keshvi Kharwar

SHED

Rahul Popaniya

Studio Shunya

Imran Jatu

SHED

Siddhant Shah

Offside Motors

Chitra Nihalani

SHED

Abhirup Dutta

The Vernacular Modern

Kush Jariwala

SHED

The SHED is a design studio expressing itself in objects, furniture and spaces using practices and materials observed through manual methods of making. The studio was founded as an independent practice by Priyanka Shah in 2014 soon after graduating from Parsons, New York in Architectural Design.

Today, the studio has grown to be a full-fledged atelier, composed with architects, artists, sculptors, furniture designers, carpenters, lathe turners and other material-specific artisans all synchronizing towards realizing different projects at different scales as responses to modern briefs.

